

N:\CAD Data\Standard Dwgs\Sanitary Sewer Details\SS-6.3\_Bioxide Feed System.dwg 3/28/2007 2:18:34 PM

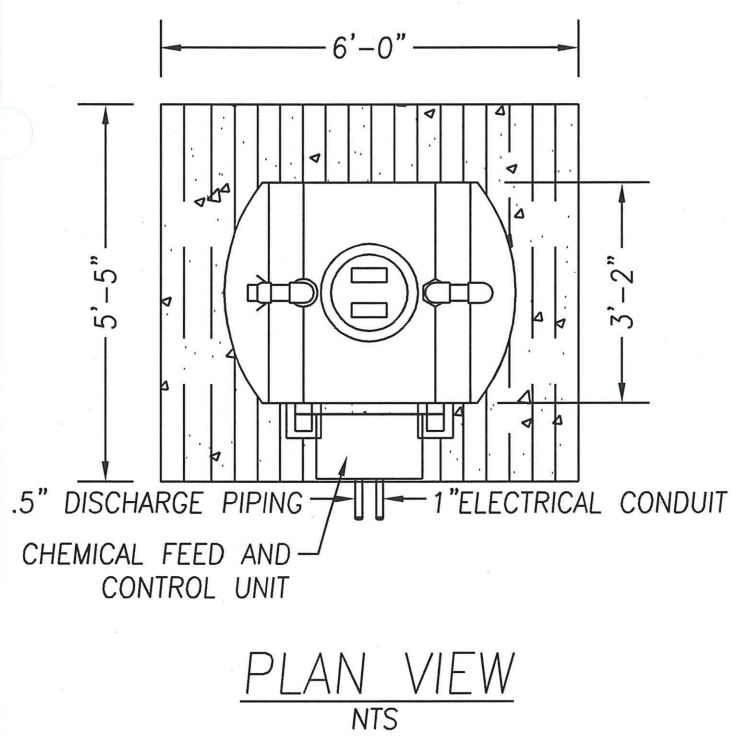
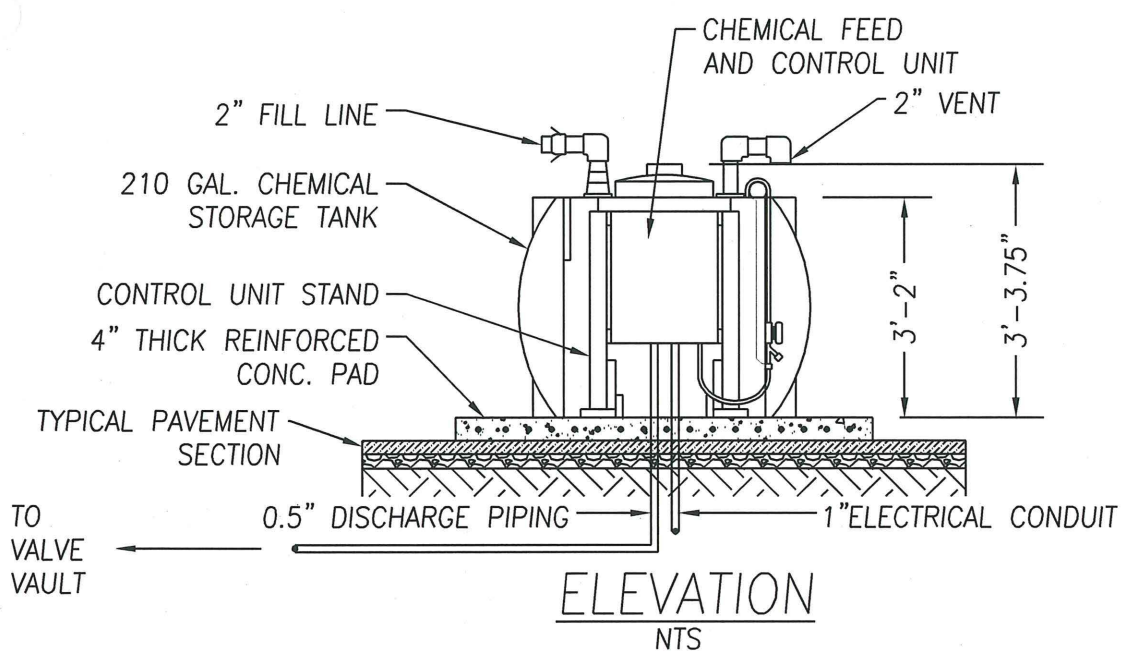

NOTES:

1. ALL PIPING AND APPURTENANCES PVC, SCHEDULE 80, UNLESS SPECIFIED OTHERWISE.
2. UTILIZE SWEEPS ONLY (NO ELBOWS) FOR CONDUIT DIRECTIONAL CHANGES.
3. FURNISH AND INSTALL ALL NECESSARY WALL AND SLAB OPENINGS, SLEEVES AND SEALANT.
4. FURNISH AND INSTALL ALL NECESSARY HANGERS, SUPPORTS, AND BLOCKING FOR PIPING.
5. ALL HARDWARE REQUIRED FOR INSTALLATION SHALL BE STAINLESS STEEL.
6. CONTACT SUPPLIER (US FILTER/DAVIS PRODUCTS) TO DETERMINE WHICH PORTIONS OF THE INSTALLATION MUST BE DONE BY OTHERS.

**BIOXIDE FEED SYSTEM**

PLAN #

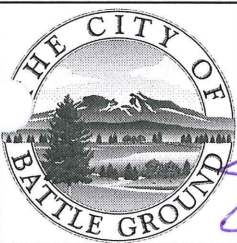

CITY OF BATTLE GROUND  
APPROVED

*[Signature]*  
CITY ENGINEER                      DATE

REVISIONS:	DATE:	DRAWN:	DESIGNED:
1	3/28/07	JMH	MCH

SS-6.3