

N:\CAD Data\Standard Dwg\Sanitary Sewer Details\SS-2.1\_Top Slab MH.dwg, 3/28/2007 1:59:24 PM

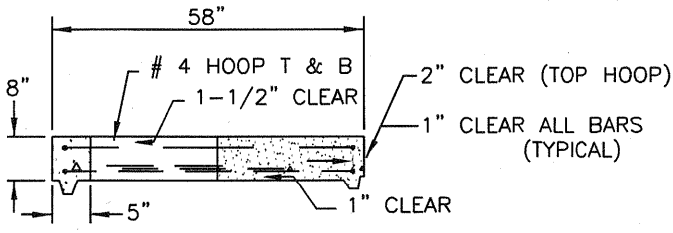

SECTION A-A

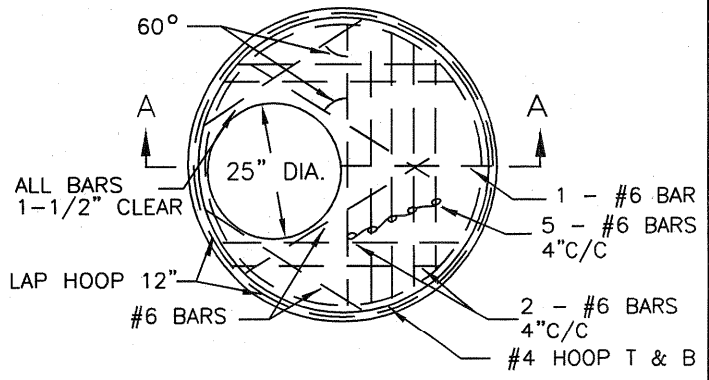

UNIT "MH"

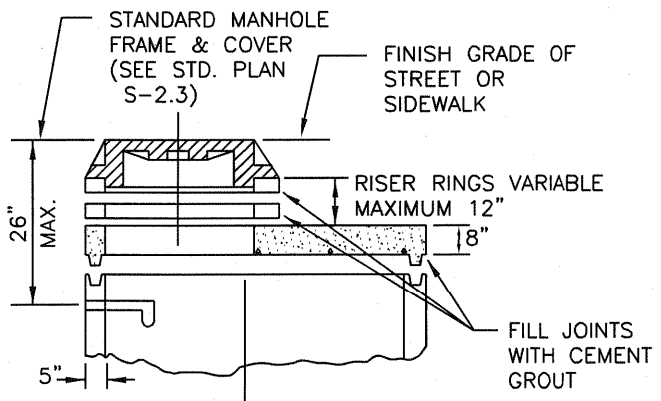

FLAT SLAB ALTERNATE

NOTES:

1. ALL PRECAST SECTIONS SHALL CONFORM TO THE REQUIREMENTS OF ASTM C-478. ALL POURED IN PLACE CONCRETE SHALL HAVE A 28 DAY STRENGTH OF 3000 P.S.I. & 2" TO 4" SLUMP.
2. ALL REINFORCING SHALL BE GRADE 40 STEEL.
3. MANHOLES UNDER 6'-0" IN DEPTH FROM RIM TO SHELF SHALL HAVE UNIT "MH" TOP SLAB IN LIEU OF CONE.
4. RAINGUARD REQUIRED. SEE DETAIL SS-2.0
5. REFER TO STANDARD DETAIL PLAN SS-2.0 FOR JOINT SEALING REQUIREMENTS.
6. WHIRLY GIG® MANHOLE RISER COLLAR SYSTEM MAY BE USED IN PLACE OF RISER RING.

TOP SLAB FOR STD. PRECAST MANHOLE

PLAN #

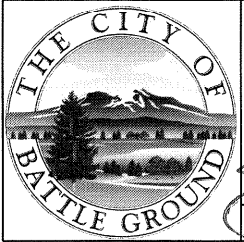

CITY OF BATTLE GROUND APPROVED

*[Signature]* 3-28-07  
CITY ENGINEER DATE

REVISIONS:	DATE:	DRAWN:	DESIGNED:
1	8/12/98	BSG	GGH
2	8/30/05	ALL	MCH
3	3/28/07	JMH	MCH

SS-2.1